



**STORAGE, ERECTION, OPERATION
AND MAINTENANCE MANUAL FOR
CENTRIFUGAL FANS**

MODEL - MXE

CUSTOMER :



CONTENTS

1	SAFETY	5
1.1	General	6
1.2	Description of symbols and pictograms	6
1.3	Start - up	6
1.4	Servicing	7
1.5	Cleaning	7
1.6	Electrical Safety	7
1.7	Description of labels and plates	8
2	APPLICATION	9
2.1	Design conditions	9
2.2	Warranty	9
3	DESCRIPTION	9
3.1	Design	9
3.2	Options	10
4	ASSEMBLY AND INSTALLATION	10
4.1	Scope of supplies	10
4.2	Transport	10
4.3.1	Storage	11
4.3.2	Stand - by operation	11
4.4	Installation site	11
4.5	Pipes connected to the fan	11
4.6	Electrical connection	11
4.7	Inspection	12
4.7.1	Mechanical testing	12
4.7.2	Electrical testing	12
5	START-UP	13
5.1	Putting the fan into the operation	13
5.2	Putting the fan out of operation	13
5.3	Transient behaviour	14
5.3.1	General	14
5.3.2	Direct starting	14
5.3.3	Star-delta starting	14
6.	CARE AND MAINTENANCE	15
6.1	Lubrication	15
6.1.1	Drive motor	15
6.2	Troubleshooting	16
6.3	Queries/sending-out of fitter	18



SAFETY PRECAUTIONS

The operation and maintenance of machinery of any kind requires a person to be cautious and aware of the damages that exist. In order to avoid injuries to personnel and damage to machinery, the following precautions are necessary.

1. Never apply power to the fan motor for any reason until the fan has been completely installed in its system, and the system inspected to be sure that no debris has been left in the fan and ducts, and it is known that the inspection doors at the inlet and outlet of the air passages are shut. The usual procedure is to remove the fuses from the disconnect switch and open its safety isolation switch until the installation is completed and inspected.
2. Start the fan momentarily and disconnect it. Observe rotation of wheel or the drive rotation is correct. Do not allow the fan to run backward, except momentarily.
3. Do not open or access inspection doors while the fan is running.
4. Always open the disconnect switch and lockit in the open position with a padlock before doing any service or maintenance work on the fan.
5. After service of any kind make certain that all adjustments have been properly made and tightened, inspection doors closed, there is no debris in the air passages and all tools have been removed before unlocking the disconnect switch to place the fan in operation.
6. Make a periodic inspection of the fan wheel, bearings and coupling to be sure that corrosion has not set in to weaken them. Where there are signs of corrosion there is danger of mechanical failure. Corroded parts should be replaced.
7. Always use caution in every maintenance or operational procedure.

1.1 GENERAL

The fan meets the technical safety standards applicable in the EC at the time of delivery. The rules and regulations for the prevention of accidents applicable at the time of delivery were taken into account in the fan design.

The technical design meets DIN 24166 standard "Technical delivery conditions for fans".

It is not allowed to modify the original condition of the without the approval of Reitz. The warranty expires when parts other than original Reitz spare parts and/or purchased parts not corresponding to the original parts are used.

The operating manual and any required supplementary manuals must be available to the operator.

It must be ensured that fans which are installed at high levels can only be reached via stages especially installed for this purpose.

All devices and installations provided to prevent noxious substances from escaping must be checked before the fan is put into operation.



Do not bypass, loosen or remove guards and protective devices.

Do not open inspection ports and/or other openings when the fan is in operation.

1.2 Description of symbols and pictograms



This symbol draws your attention to dangerous situations. The operation concerned may endanger persons and cause injuries.



This symbol is used to indicate that the work must be carried out by a trained and qualified electrician.



This symbol is followed by supplementary information.

1.3 Start-up

The fan may only be put into operation (also for testing) when the inlet and outlet ports are provided with suitable guards/plate shutters or when pipes are connected to them.

Before the fan is started the housing and all pipes connected to it must be checked. They must be dry and free of screws, bolts, tools and other foreign substances.



Disregarding the above instructions may cause accidents and destroy the fan. Observe the safety regulations for electrical machines and equipment.

(→ Electrical safety)

1.4 Servicing

The fan may only be serviced when the electrical system is dead, i.e.;

- turn off the electrical machines and ensure that they cannot be switched on again.
- wait until the rotor has come to a standstill,
- remove the motor fuse,
- disconnect the power supply cable for the motor.

After servicing all guards and protective devices must be installed and all pipes must be connected again. All bolts and nuts must be tightened. Close all inspection openings and tighten the bolts and nuts.

The fan can then be put into operation again.

1.5 Cleaning

Do not clean moving parts when the fan is in operation.

Before cleaning the fan must be put out of operation. Ensure that the fan cannot be switched on again accidentally.

Only use suitable detergents and cleaning materials.
Remove any dirt wiped off the impeller from the fan housing.



If material is sticking to the impeller or the impeller is worn, the fan may be seriously damaged by unbalance. It is therefore recommended to clean and check the fan for unusual vibrations at regular intervals.

1.6 Electrical safety

The user has to ensure that the fan is only connected and serviced by a qualified electrician in accordance with the rules and regulations applying to electrical equipment.

The user must also ensure that the fan is operated in accordance with electro-technical rules and regulations.

Do not touch/work on live parts.

- Interrupt the power supply to the fan and use mechanical means to ensure that power supply cannot be switched on again.
- Use a voltage tester to check that the circuit is dead.
Connect and short the work site to earth.
- Only use the fuses indicated in the electric circuit diagram.
- Check the condition of the visible cables before the fan is started.
- Replace damaged cables.

Damaged and/or defective electrical equipment must be repaired or replaced immediately. If the damaged equipment represents a risk, the fan may not be put into operation before the defect is repaired.

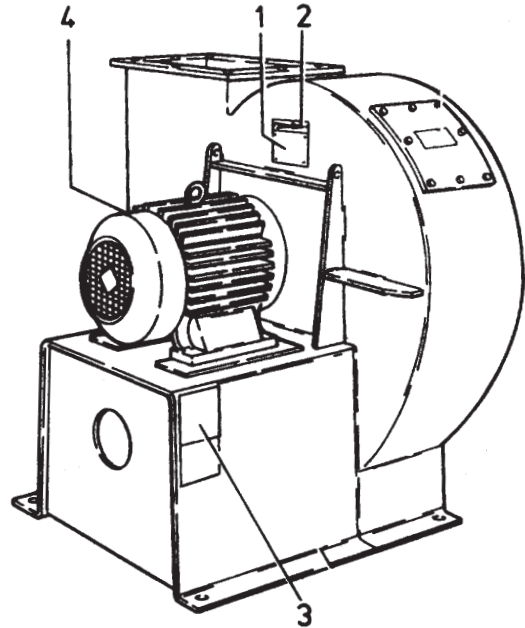

1.7 Description of labels and plates

The following plates are attached to the fan:

1. Nameplate
The nameplate indicates

Reitz India Ltd.	
HYDERABAD - INDIA	
CLIENT :	<input type="text"/>
WORK ORDER :	<input type="text"/>
CONSULTANT :	<input type="text"/>
YEAR OF :	<input type="text"/>
MANUFACTURE :	<input type="text"/>
MEDIUM HANDLED:	<input type="text"/>
ST. PRESSURE :	<input type="text"/>
SHAFT POWER:	<input type="text"/>
TAG NO :	<input type="text"/>
MODEL :	<input type="text"/>
DENSITY :	<input type="text"/> KG/M³
FLOW RATE:	<input type="text"/> M³/HR
OPERATING TEMP :	<input type="text"/> °C
RPM :	<input type="text"/>

Further data are indicating on the master card of the fan.

2. Arrow showing the sense of rotation of the impeller.
3. Company emblem
4. Motor nameplate

2. APPLICATION

2.1 Design Conditions

The fan is designed, tested and delivered in accordance with the instructions given in the order.

The instructions indicated in the order have been entered on the master card of the fan. It is not permitted to change the conditions under which the fan is to be used (e.g. another medium). These conditions are also entered on the master card.

2.2 Warranty

The warranted data refer to single values and testing conditions in accordance with the applicable DIN standards and/ or codes of practice. The special characteristics and local conditions of the plant in which the fan is to be incorporated must be taken into account by the plant designer and/ or planning engineer in his order.

He has to base his data on the actual operating conditions.

3. DESCRIPTION

3.1 Design

The model MX fan is a welded single-stage centrifugal fan. It is driven directly by the motor shaft on which the impeller is mounted.

The fan has connections for flat flanges acc. to DIN 24 154 R2 (edition July 90) or for flat frames acc. to DIN 24 193 R3.

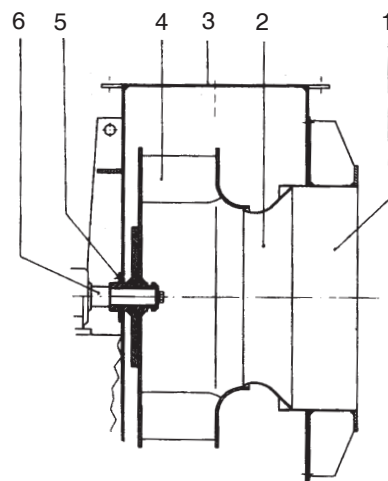
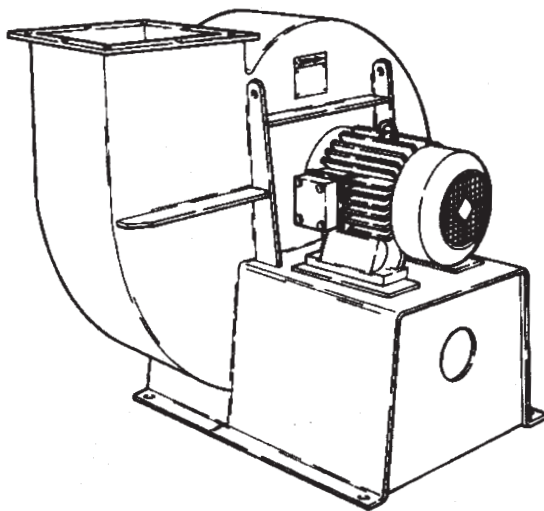

- | | |
|------------------|----------------|
| 1 - Inlet socket | 4 - Impeller |
| 2 - Inlet cone | 5 - Shaft seal |
| 3 - Casing | 6 - Shaft |

 For special designs please note the information given on the master card of the fan.

In standard designs (i.e. the temperature of the medium does not exceed +80° c) the ports for the shaft are sealed with a felt strip. For temperatures above 80° c the parts are sealed with an asbestos-free flat packing disk.

 This seal is **not** completely tight! For special shaft seals please refer to the information provided in the annex.

3.2 Options

Accessories are available to adapt the fan to certain specific plant characteristics. For additional information see (→ Annex)

4. ASSEMBLY AND INSTALLATION

4.1 Scope of supplies

When delivered the fan and accessories must be checked for damage caused by damaged packing.

Immediately report any transport damage to the forwarding agent, insurance company and manufacturer.

Check that everything indicated on the delivery note has been delivered.

In all other respects please refer to our terms and conditions for sales and delivery.

4.2 Transport

Only transport the fan with transport facilities which are appropriate for the conditions on the site where the fan is to be installed.

 Observe the applicable rules and regulations for the prevention of accidents.

For lifting and transporting the fan only ropes and/ or fork lift trucks with a sufficient lifting capacity may be used.

Only attach ropes to the fastening plates (1) especially provided for lifting the fan.

 Do not sling lifting ropes to the inlet/outlet ports or motor.

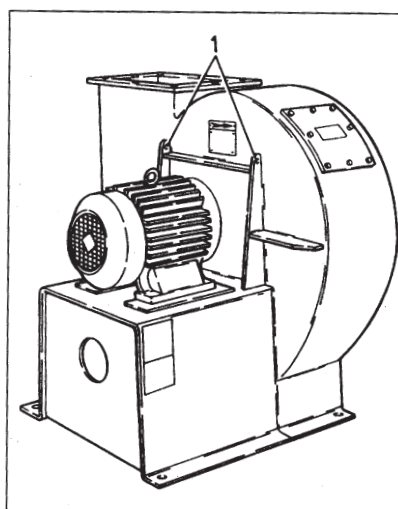

Warranty claims or claims for compensation for any damage caused by the use of unsuitable means of transport or caused by improper handling will not be accepted.

4.3.1 Storage

If the fan is not installed and / or put into operation immediately it must be stored in a dry place which is free of vibrations.

In case of long-term storage please note the storage and preservation instructions for motors.

4.3.2 Stand-by operation

In case of prolonged standstill periods please note the relevant instructions for the storage of motors.

4.4 Installation site

The installation site must be level and have a sufficient load bearing capacity. There must be enough room for assembly and maintenance work. The impeller must be easily accessible.

4.5 Pipes connected to the fan



When attaching the pipes to the fan care must be taken that the fan is not distorted.

- Remove the transport shutters from the connection ports.
- Install the pipes in a manner ensuring that they are exactly aligned with the inlet and outlet ports of the fan.
- Connect the pipes with flexible couplings (compensators) to the inlet and outlet ports of the fan(option).
- Install a baffle in the suction line (inlet side) to prevent contractions (underpressure).
- Check if the baffle has to be installed on the pressure (outlet) side.

4.6 Electrical connection



The fan may only be connected up to the electrical system by a qualified electrician. The drive motors are usually installed in the manufacturing works. The works warranty does not apply if the customer installs the motor.

(→ Chap. Electrical safety)

The operating instructions of the motor manufacturers must be observed.

The motor is connected in accordance with the circuit diagram inside the terminal box (1). The customer has to check that his power network and the switch gear and monitoring devices are sufficiently dimensioned to cope with the transient behaviour and current peaks. It must be ensured that the supply of cooling air to the electric motor is not hindered.

- The power supply cable for the fan must be installed in accordance with VDE regulations or any locally applicable legal stipulations.
- Compare the local mains voltage with the voltage indicated on the rating plate (2) of the fan.
- Connect the fan as shown on the circuit diagram inside the terminal box (1).
- Earth the fan in accordance with the regulations issued by the local power supply company.
- Check the speed and sense of rotation.
- Check the transient behaviour and starting time.
- Provide for a motor protection system.

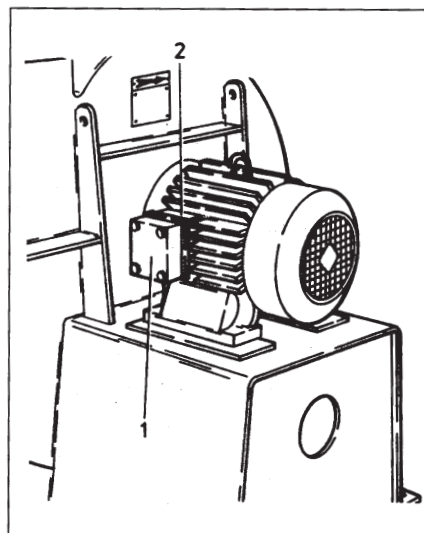

4.7 Inspection

4.7.1 Mechanical testing

Check the fan after it has been assembled and installed.

- Check the attachment of the fan to the foundation.
- Check if the impeller rotates freely (turn it with the hand).
- Remove any foreign objects from the fan housing.
- Check all screw couplings and bolted connections.
- Check all pipe connections.

4.7.2. Electrical testing



The electrical system of the fan may only be tested by a qualified electrician.

- Check the operating voltage.
- Check the earthing.
- Check the size of the fuses.

If the fan is not put into operation immediately after it has been assembled and installed, it must be secured against unauthorized use and covered with a tarpaulin.

5. START-UP

5.1 Putting the fan into operation



The fan may only be put into operation by qualified and skilled staff. Before the fan is put into operation the staff must check that the fan is in good working order.

The rules and regulations for putting electrical machines into operation must be observed.

- Check the safety systems.
- Close the choking elements (if provided).
- Switch on the master controller.
- Switch on the fan.

The fan may only be switched on when the pipes are connected and when it is certain that there will be a sufficient plant resistance after the fan motor has reached its full operating speed.

- Check the sense of rotation of the motor when the fan is started up for the first time (the fan must rotate in the direction indicated by the arrow).
- Check the power consumption. The maximum permissible power consumption may not be exceeded.

5.2. Putting the fan out of operation

- Switch off the fan.
- Turn master controller to "OFF" and secure it against unauthorized use.

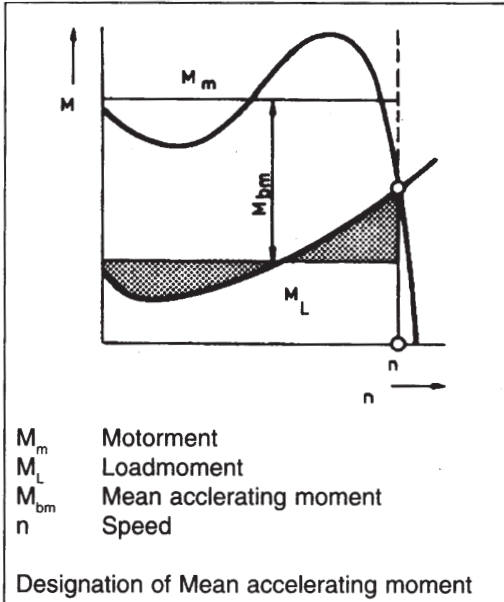

5.3. Transient behaviour

5.3.1 General



The fan can only be started when a sufficiently high moment of acceleration is available from the moment when the **nominal speed** is reached.

It is recommended to start the fan with the choking element closed.



The customer has to check that his power network, switchgear, monitoring devices (if available) and cable cross sections are dimensioned to cope with the transient behaviour and current peaks.

5.3.2 Direct starting

Direct starting of the fan motor not only causes a high starting torque but also a high starting current.

During start-up the starting current may be 6 to 8 times as high as the nominal current (depending on the type of rotor).

This high power input must be taken into account when the fuse sizes are determined.

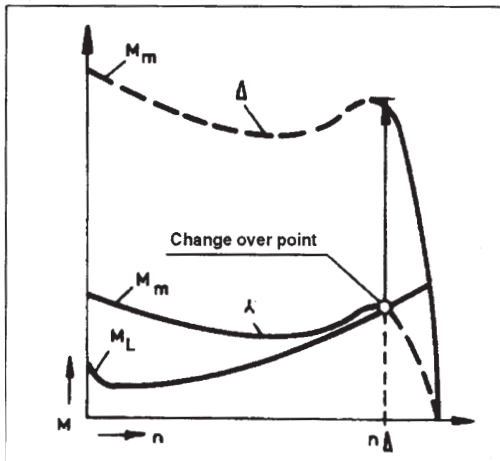

5.3.3 Star-delta starting

During star-delta starting the drive motor only provides for 1/3 of the starting torque in the star connection. At a certain starting speed the load moment of the fan exceeds the starting torque of the motor. The motor does not accelerate. At this point the motor has to be changed over to the delta connection. The



current peak which is then obtained is clearly lower than the one occurring during direct starting.

6. CARE AND MAINTENANCE

6.1 Lubrication



The fan must be checked at regular intervals (depending on the operating conditions).

6.1.1 Drive motor

The motor must be serviced in accordance with the motor's lubricating instructions.

6.2 Troubleshooting

Malfunction	Possible cause	Action
Unsteady operation of fan.	Material sticking to impeller blades.	Carefully clean impeller.
	Worn impeller.	Replace impeller.
	Impeller deformed by heat.	Replace impeller.
	Fan distorted because of uneven foundation.	Remove fan from foundation and level foundation again.
	Incorrect setting of rubber-metal buffers or spring isolators.	Correct setting.
	Strain exerted by connected pipes.	Use flexible pipe connections (compensators).
	Seal is faulty or worn.	Replace seal.
Medium escapes at the shaft seal.	Impeller rubs against nozzle.	Loosen housing cover and inlet re-align, check and correct pipe if necessary.
Fan produces a grinding noise.	Motor noise.	Check if bearings are damaged and replace bearings if necessary.
	Air volume too much.	Reduce air volume using a choking element until the permissible power input is reached.
	Different speed with 60 Hz mains.	Check frequency.
The power input indicated on the rating plate is constantly exceeded.	Improper connection of drive motor.	Check connection.
	Motor does not change from star to delta connection.	Shorten change-over time from star to delta.
	Fan operates against insufficient plant resistance.	Close choking elements or install additional plate shutters.
	Motor protection system is not strong enough.	Cable cross section and protective system must withstand starting current during acceleration.
Fan does not accelerate.		

6.2 Troubleshooting

Malfunction	Possible cause	Action
	<p>Starting time is too long.</p> <p>Faulty drive motor.</p> <p>Starting/re-starting when fan is hot.</p> <p>Starting current too high.</p>	<p>Close choking elements, check starting torque of MA/MN motor.</p> <p>Check motor and replace if necessary.</p> <p>Switching frequency too high, let motor run through (control via choking element).</p> <p>Wrong voltage. Provide star-delta starting, local mains not strong enough.</p>



6.3 Queries / Sending-out of fitter

If you have any queries, want to order spare parts or have a fitter sent out to you, your request should include the following details:

- Serial No. of the fan, (5 or 6-digit number indicated on the master card of the fan or on the model plate).
- Exact address of the user.
- Name of the person our fitter should get in touch with.
- If possible a description of the malfunctions (visible/audible). An exact description will allow us to help you more quickly and efficiently. Information sent out by FAX will be very much appreciated.

Please contact:

Reitz India Limited.

VII Floor, Block - A, Q - City, Gachibowli,
Nanakramguda, Hyderabad - 500 046. India
Tel: +40- 4488 1888, Fax: +40- 4488 1888
E-mail: info@reitzindia.com
Websites: www.reitzindia.com www.reitz-ventilatoren.de

Bengaluru +99002 12572	Mumbai + 93222 95348
Chennai +93810 63065	New Delhi + 93100 10559
Kolkata +94330 32474	

Collaborator & Joint Venture Partner (Centrifugal Fans)

M/s Konrad Reitz Ventilatoren GmbH & Co. KG
Konrad Reitz-Str.1, OD-37671 Hoexter / Albaxen, Germany
Tel: 05271 964000 Fax: 05271 964229
E-mail: reitz.ventilatoren@t-online.de
Website: www.reitz-ventilatoren.de